

Superconducting Cable ComEd Vision

US Perspective on Superconductors



Daniel P. Brotzman

Manager of Transmission Line Engineering
ComEd

Mike Bauer

Managing Director
AMSC





US Perspective on HTS Technologies



Gridtec
Solutions™

Key Milestones

2006 – AEP, Ohio



2008 – LIPA, Long Island



2011 – KEPCO, Korea



2011, US Navy



2014, RWE, Germany



Today, ComEd Chicago



Key Drivers for HTS in the US

The Aging Electric Grid

- Environmental Concerns
- Resiliency in the face of aging equipment
- Compact
- Difficulty of Siting and Installations
- Underground Installations Favored
- Increasing Fault Current



The Need to Evolve the Electric Grid

- Higher Reliability at Lower Project Costs
- Higher Capacity with Smaller Equipment
- Fault Current Management
- Operational Control and Flexibility



Electrification of the Naval Fleet

- Better and More Efficient Solutions
- Higher volumes of wire result in lower wire costs
- REG Projects drive performance and reliability improvements
- REG projects will reduce HTS costs for Naval applications (and vice versa)

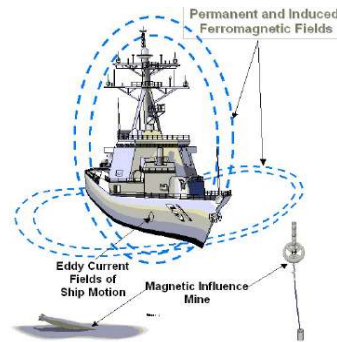

Global Demand for Renewable Energy

- New power transmission infrastructure needed
- REG technology can be expanded to large scale, long distance projects
- HTS technology ideal for HVDC cable solutions:
 - High Power
 - High Efficiency (Low Losses)
 - Ideal for Long Distances
 - Controllable, Bi-Directional
 - Underground





US Utility Discussions and Activities

Central Region
7 Expressions of Interest
3 Investigating Applications
1 Active Deployment Study

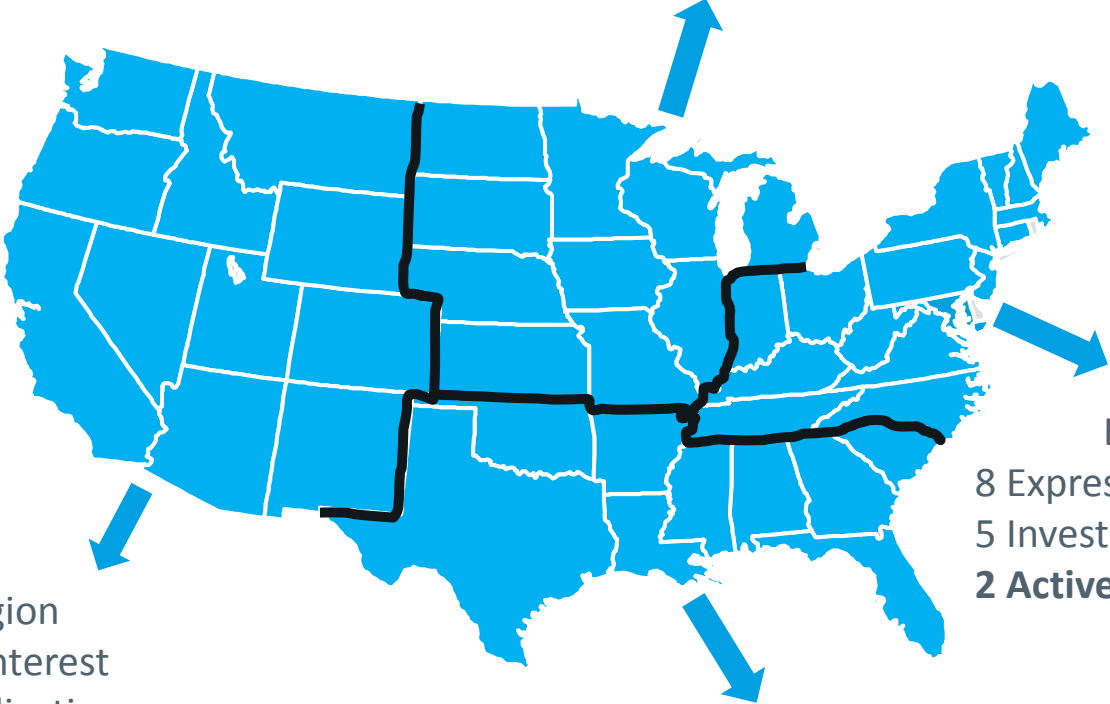

Eastern Region
8 Expressions of Interest
5 Investigating Applications
2 Active Deployment Studies

Western Region
11 Expressions of Interest
6 Investigating Applications
4 Active Deployment Studies

Southern Region
8 Expressions of Interest
4 Investigating Applications
1 Active Deployment Study

Navy Application - Degaussing

Understanding the Inherent Problem

Problem

Ship moving through the earth's magnetic field creates a magnetic disturbance that is detectable by enemy magnetic mines

Solution

Generate magnetic field with degaussing coils to mask ship's magnetic signature

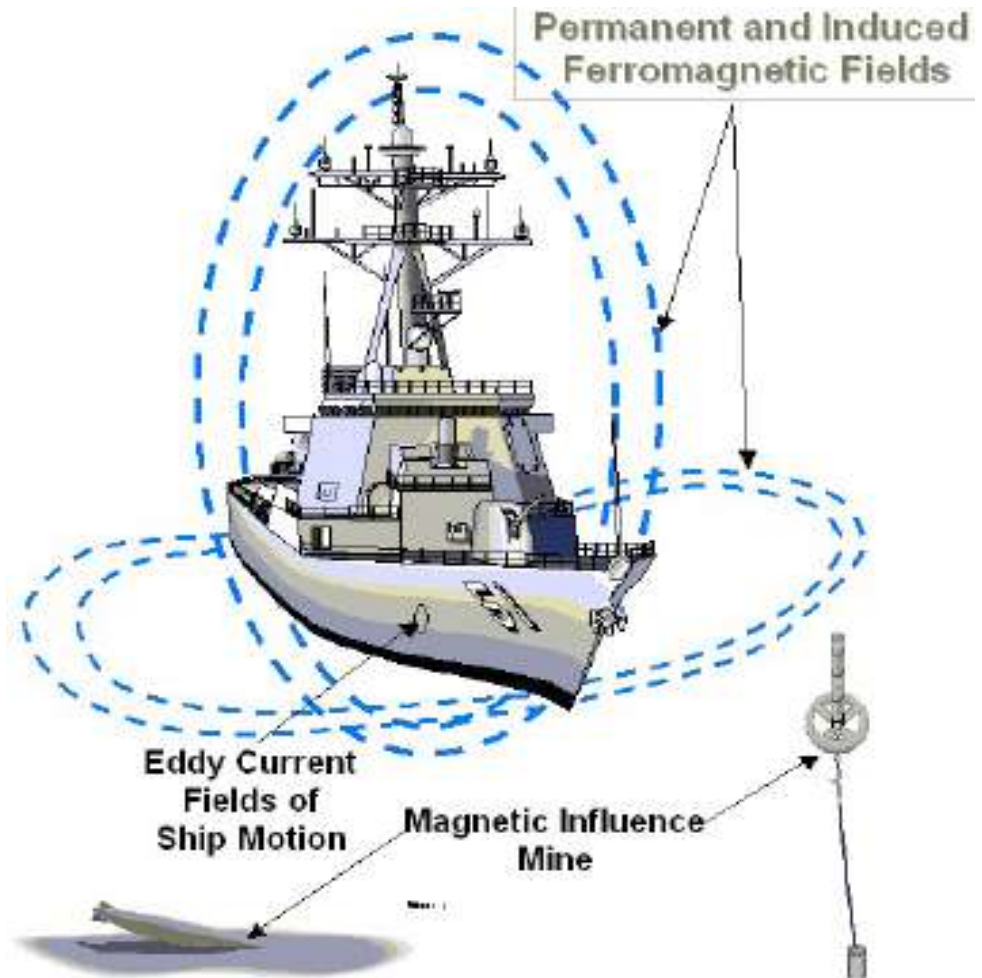



HTS Degaussing

A Decade of Development and Investment

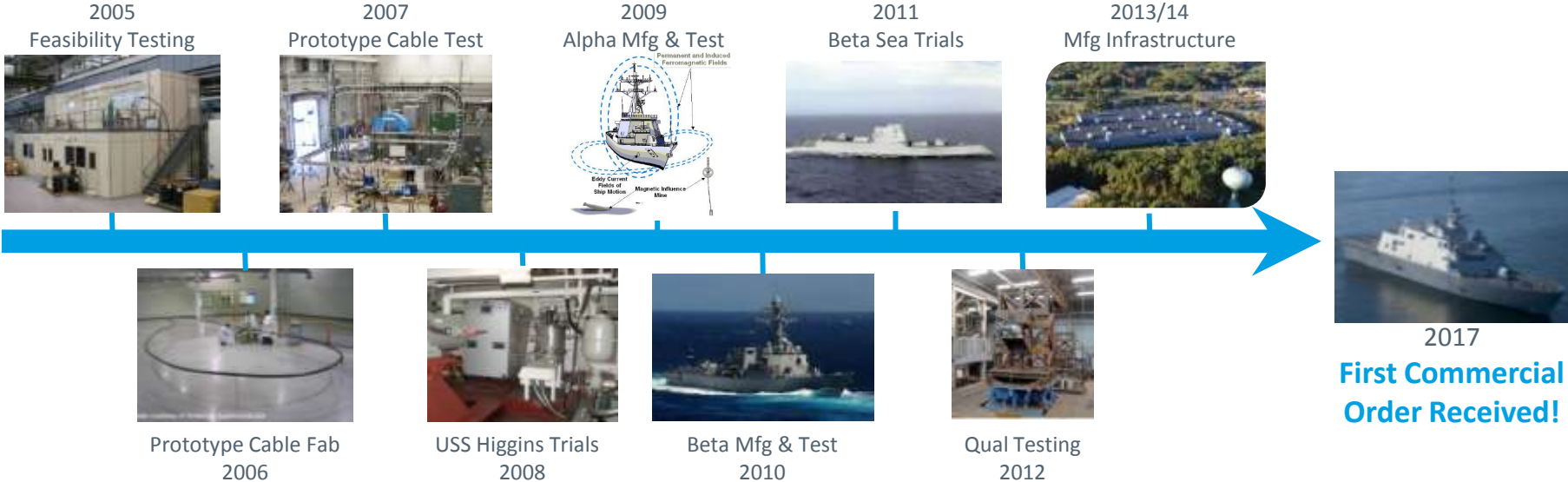

COMMON CRYOGENIC BUILDING BLOCKS (C²B²) USED IN HTS DG

- ➡ Propulsion Motors
- ➡ Power Cables
- ➡ ADV. Degaussing

Superconductor Fault Current Limiters

Unique Benefits



- Invisible to the Grid
- Reduce short circuit currents
→ lower rating equipment
- Enable grid coupling
- Allow or simplify distributed generation
- Improve safety



Superconducting Cable ComEd Vision



Daniel P. Brotzman

Manager of Transmission Line Engineering

Exelon Utilities serves ~10M customers, covering over 24,000 sq. miles, and with peak load over 53 GW



Operating Statistics

Commonwealth Edison		Potomac Electric Power	
Customers:	4,000,000	Customers:	856,000
Service Territory:	11,400 sq. miles	Service Territory:	640 sq. miles
Peak Load:	23,753 MW	Peak Load:	6,674 MW
PECO Energy		Atlantic City Electric Co.	
Customers:	2,100,000	Customers:	550,000
Service Territory:	2,100 sq. miles	Service Territory:	2,800 sq. miles
Peak Load:	8,983 MW	Peak Load:	2,797 MW
Baltimore Gas & Electric		Delmarva Power & Light	
Customers:	1,970,000	Customers:	631,000
Service Territory:	2,300 sq. miles	Service Territory:	5,000 sq. miles
Peak Load:	7,236 MW	Peak Load:	4,121 MW

Combined Service Territory

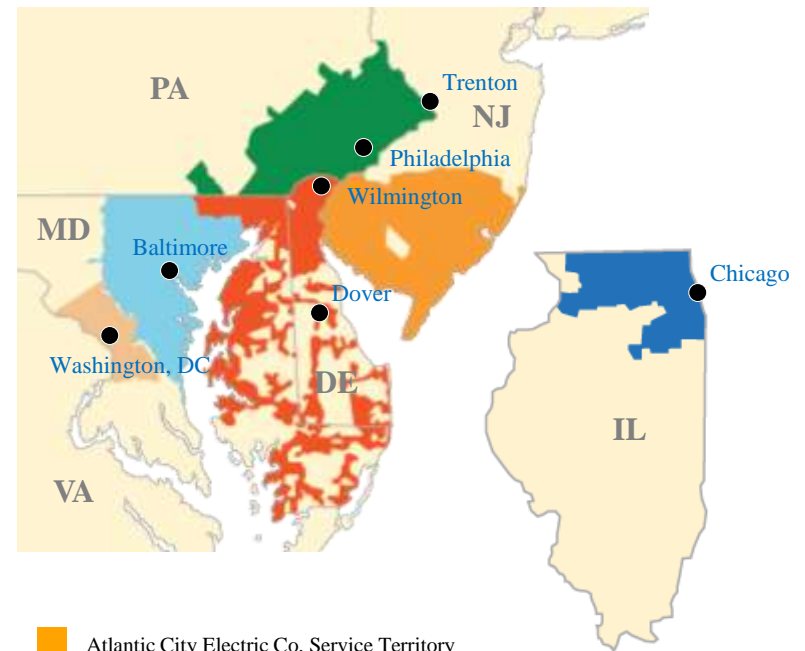

- Atlantic City Electric Co. Service Territory
- Baltimore Gas and Electric Co. Service Territory
- ComEd Service Territory
- Delmarva Power & Light Service Territory
- PECO Energy Service Territory
- Potomac Electric Power Service Territory



An Exelon Company



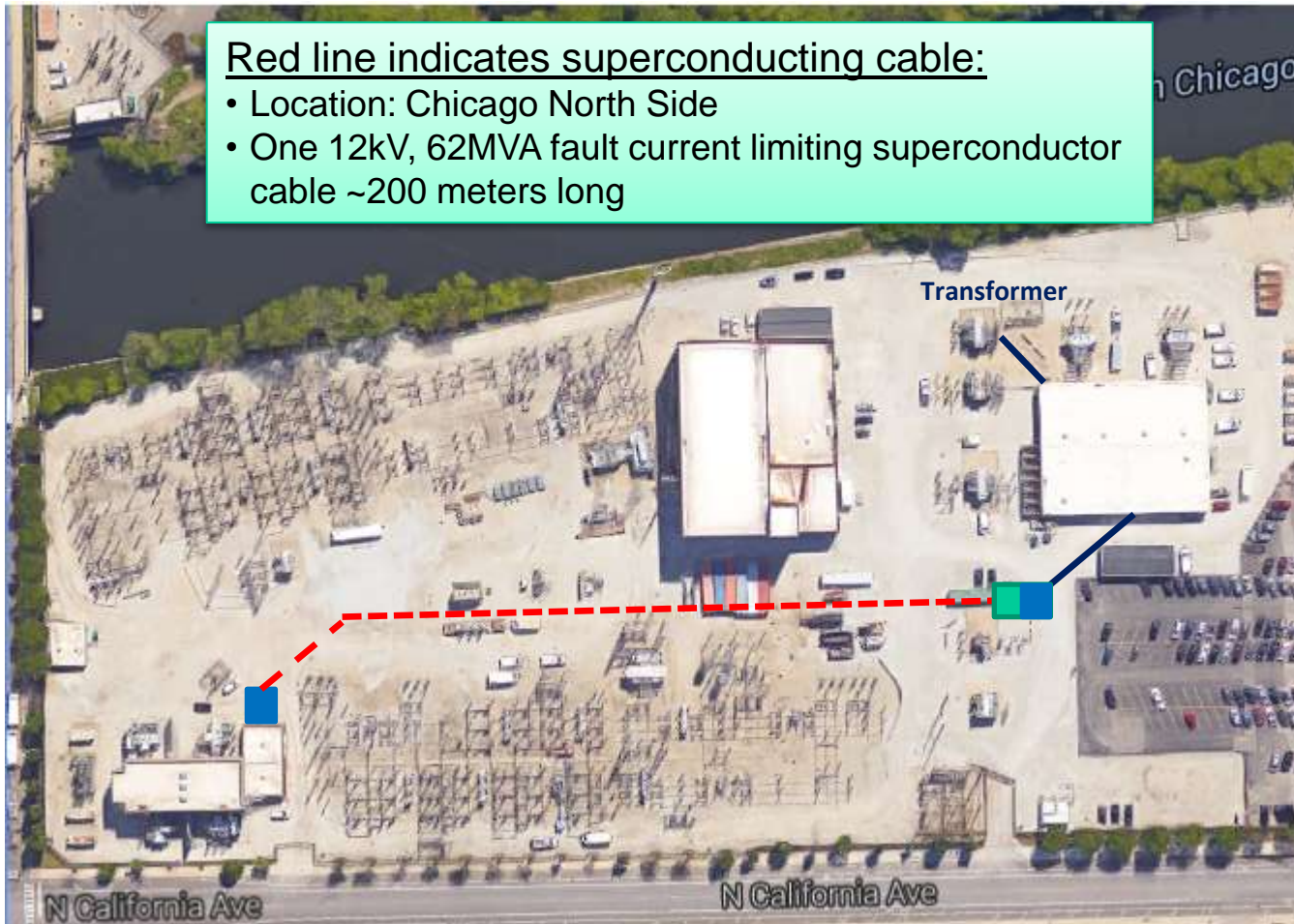

Superconductor Cable Pilot

Red line indicates superconducting cable:

- Location: Chicago North Side
- One 12kV, 62MVA fault current limiting superconductor cable ~200 meters long



Legend

-  Superconductor Cable
-  Refrigeration Building
-  Underground Cable or Bus
-  Terminations

Superconductor Future plan - Three Station Design

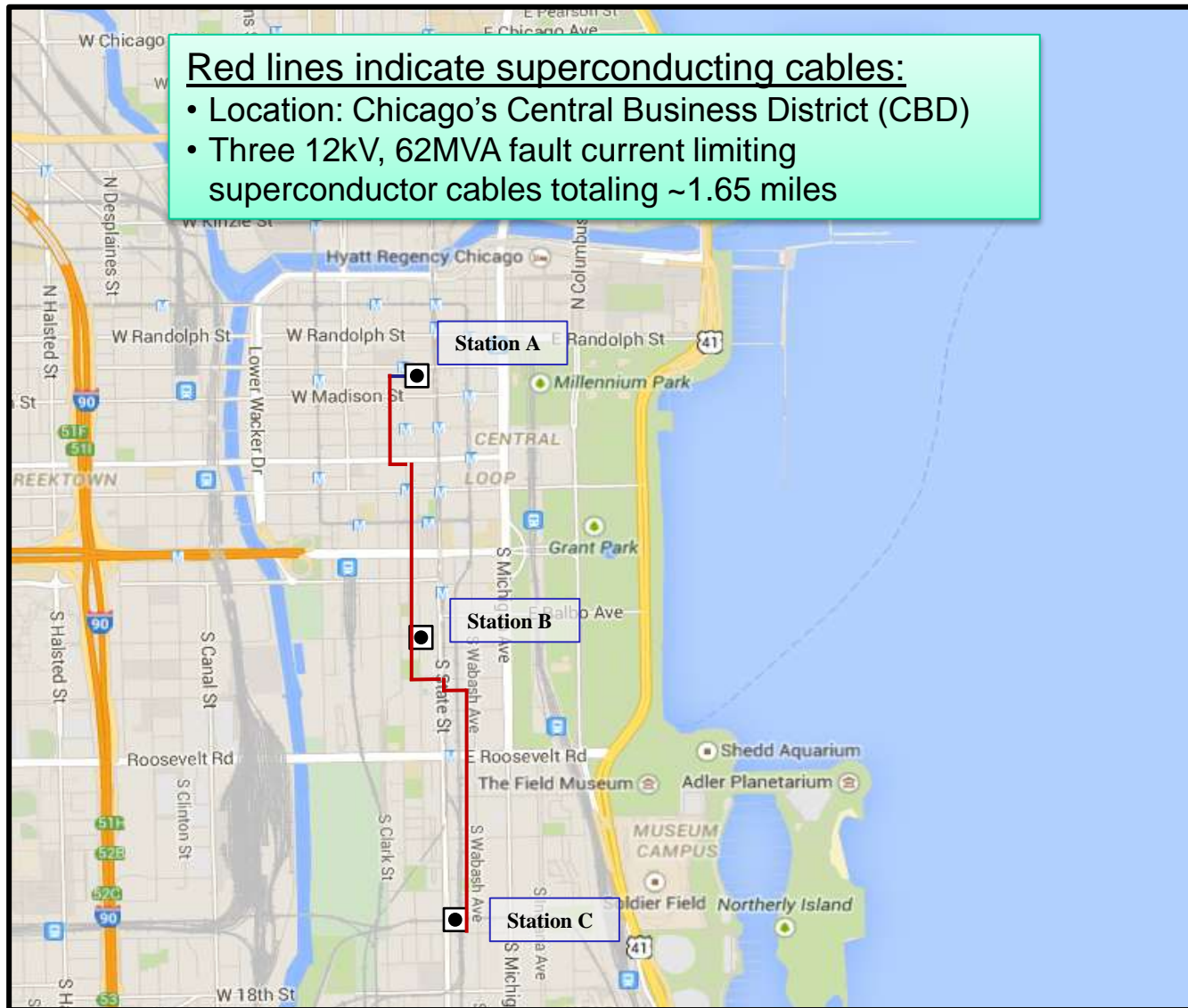

PEPCO Overview of HTS Three Sub Design

Total HTS cable length is 2.5 miles

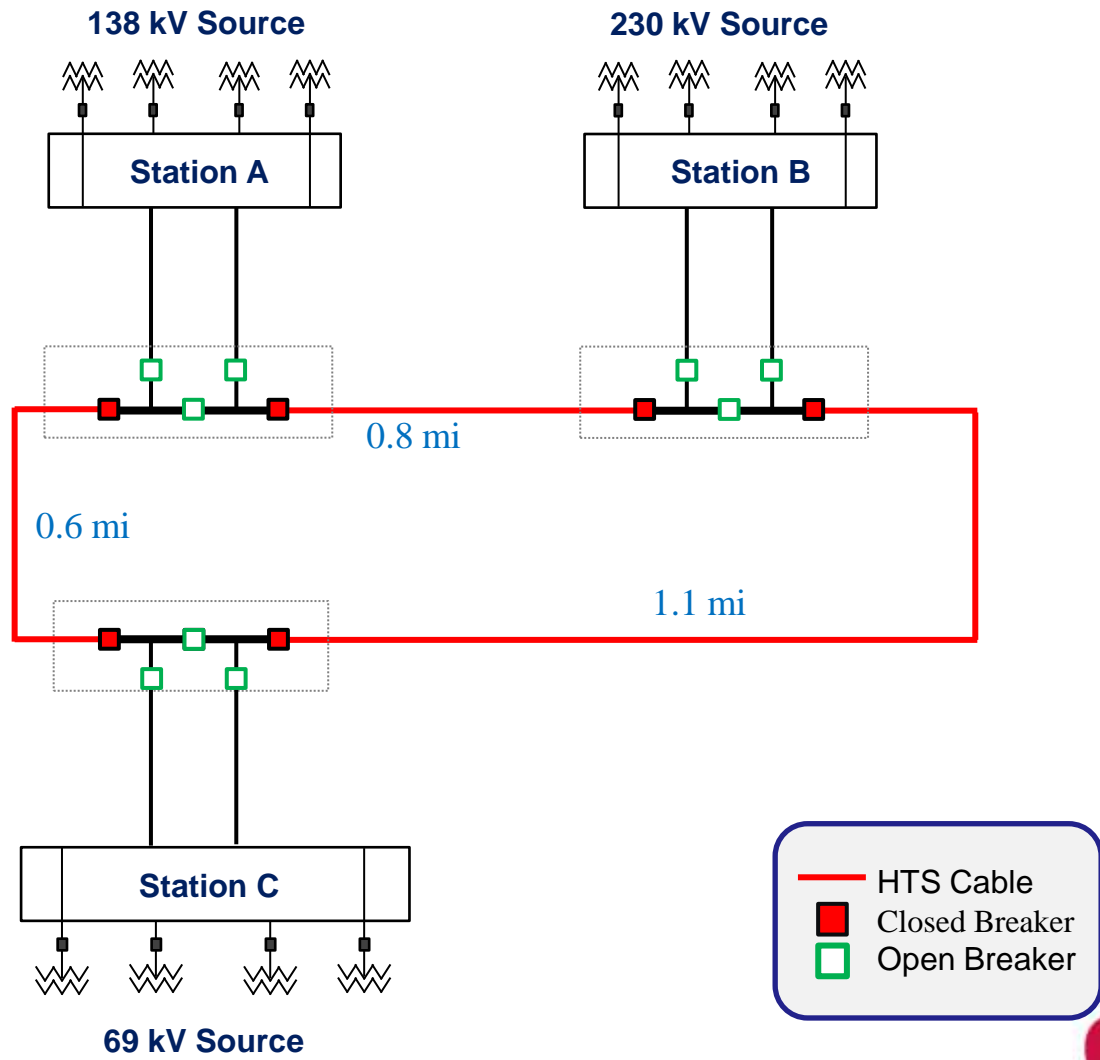

- **Underground Transmission Total Length: 388 miles**
 - Cross-Linked Polyethylene (XLPE) ~130 miles on 85 circuits with 17% at 345kV, 66% at 138kV & 17% at 69kV
 - Low Pressure Fluid Filled (LPFF) ~46 miles on 34 circuits (69kV only)
 - High Pressure Fluid Filled (HPFF) ~212 miles on 103 circuits with 5.5% at 345kV, 92% at 138kV & 2.5% at 69kV

Voltage	HPFF Cable			XLPE Cable	Duct / Pipe Size
	Static	Forced Cooled	Refrigeration		
138kV	~220 MVA	~300 MVA	~400 MVA	~160 MVA	8" pipe HPFF or 6" ducts XLPE
345kV	~550 MVA	~650 MVA	N/A	Will not fit in pipe	



Potential economically viable solutions today

- New Suburban Station that brings capacity into a City station, avoiding the expensive property expansion

Potential economically viable solutions in the future?

- Replacing an existing LPFF or HPFF cable, leveraging the existing pipe for conduit and pumping plant location for new cryogenic plants
- Directly competing against an installation of XLPE cable
- Directly competing against a new overhead installation



Total cost of ownership

- Initial capitalization costs
 - Cable
 - Cryogenics
 - Civil work
- Ongoing maintenance costs over a 40 year life
- Competition is XLPE and pipe type cable, both of which have pros and cons

Operations risks and challenges

- Level of Cryogenic system redundancy to be installed
- New technology hurdle needs to be overcome
 - Worker safety associated with liquid nitrogen
 - Community acceptance of a system with liquid nitrogen
 - Uncertainty of operational life





Technical Details of Selected Projects



Typical Cooling System Concept

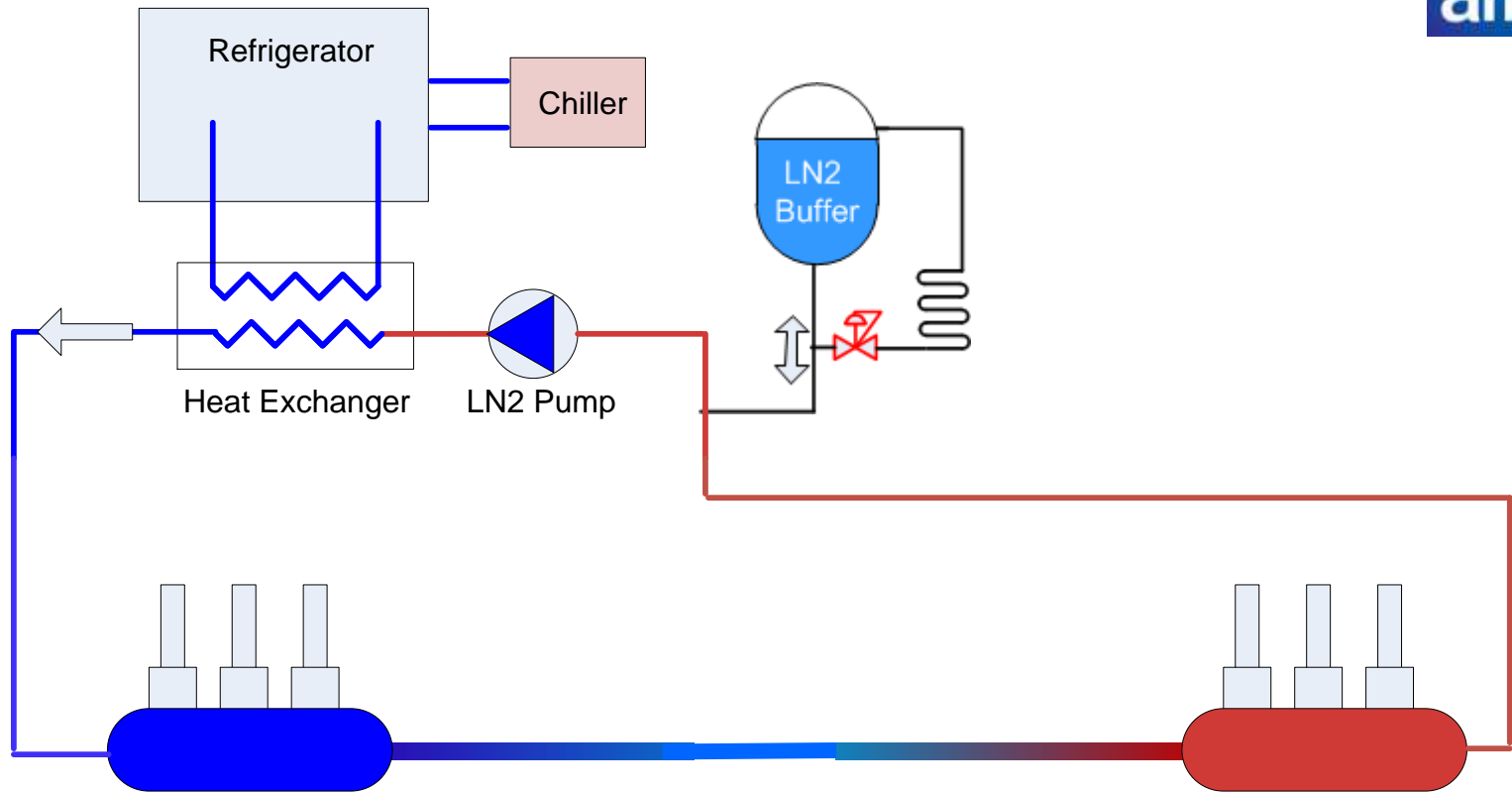

- The heat from HTS cable is carried out by circulating sub-cooled (18bar) liquid nitrogen.
- Warm nitrogen stream is re-cooled at cooling station by refrigerator
- Heat generated by refrigerator is removed by chillers.

Cooling Topology – ComEd Cable Pilot



One Close Loop Cooling Station

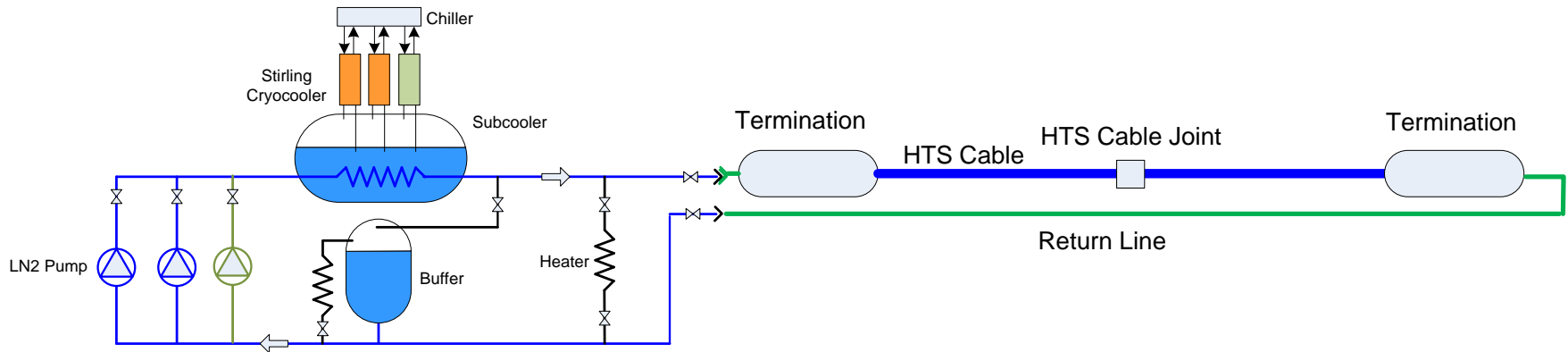

- Critical component redundancy
 - Stirling cryocooler module
 - LN2 pump
- N+1 redundancy scheme
 - In normal mode, two modules are required
 - In contingency mode, the stand-by module kicks in
 - Switching process is automatic

Electrical Operation of ComEd Future Project

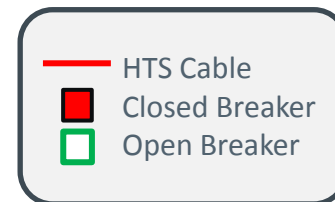
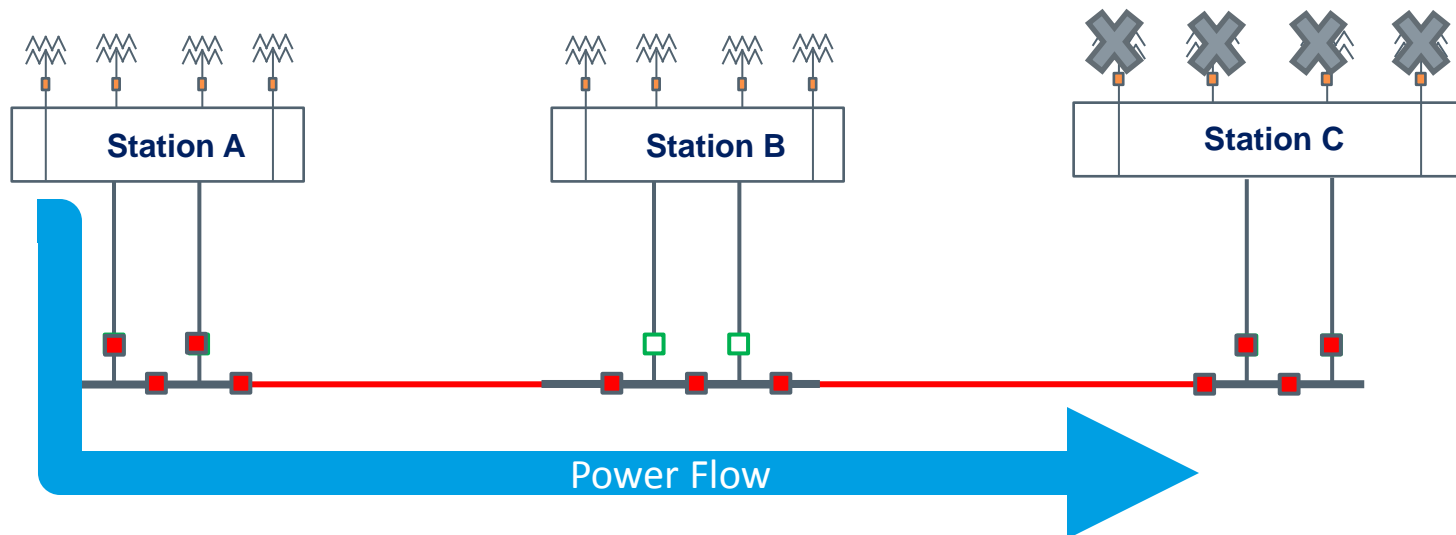

Cooling Topology – ComEd Future Project

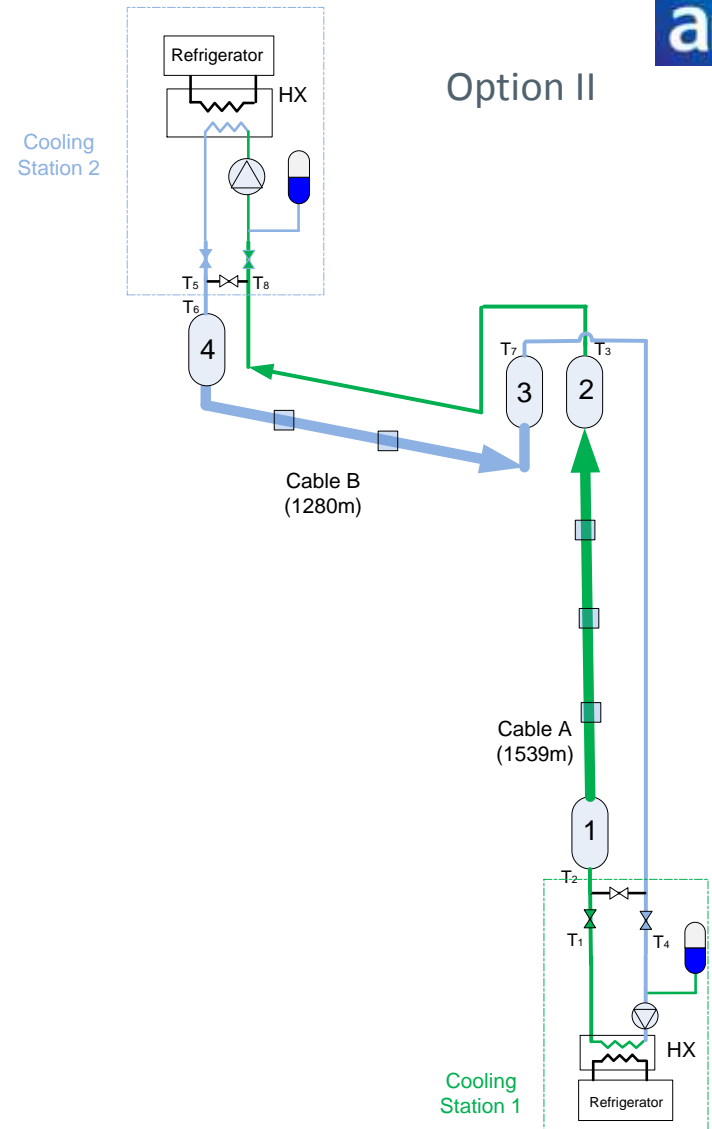
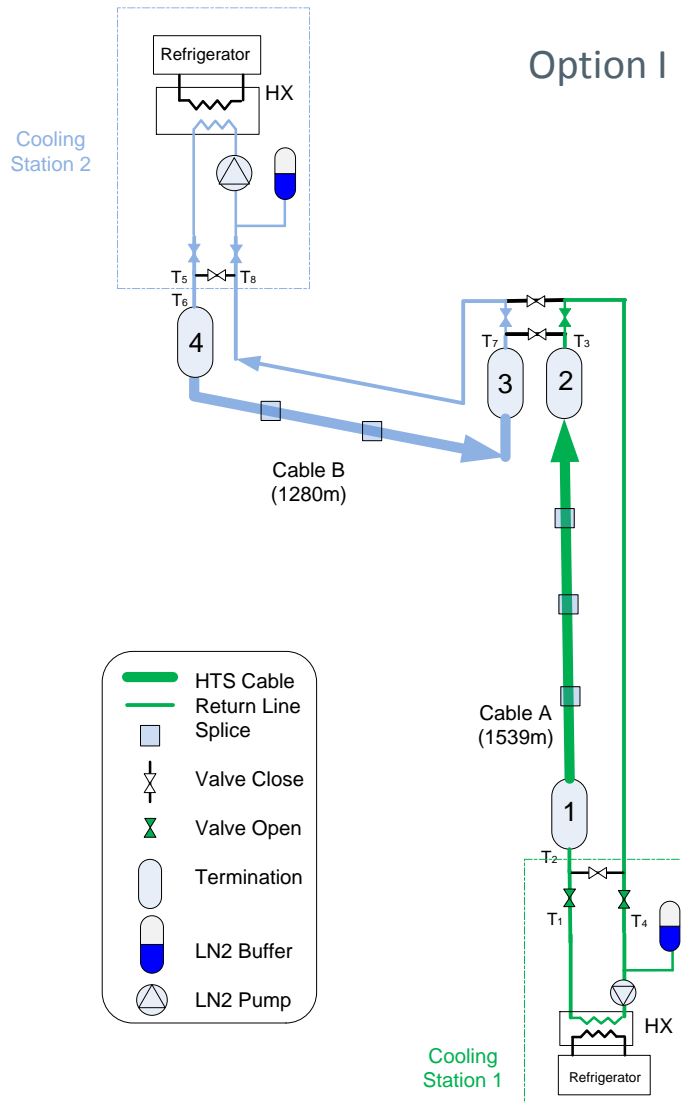

Cooling Topology – PEPCO Solution



100% redundant System

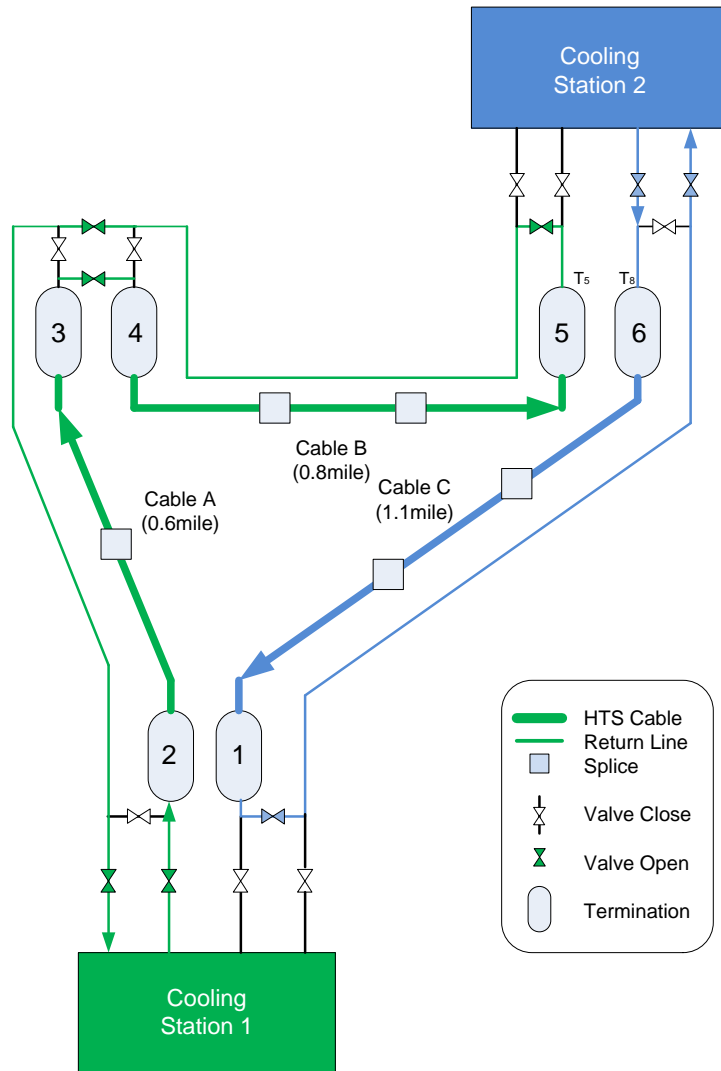

- Two 20kW@67K TB refrigerators
- System redundancy
 - In normal mode, refrigerators at partial load. Cooling station 1 cools cable A and B while cooling station 2 cools Cable C.
 - In contingency mode of lost one refrigerator, the other refrigerator ramp up cooling power to cool all three cables
 - In contingency of lost one cable, the rest cables can be still energized
 - Switching of cooling duty is automatic process

Performance of PEPCO Solution



Plan	% of Peak Load at <u>Risk</u>		
	N-2 Outage	N-3 Outage	N-4 Outage
Base Case	26%	58%	100%
With REG	0%	0%	8%